



HMS Hairpin Matching Systems

DXE-HMS-1P, DXE-HMS-2P, DXE-HMS-4P

DXE-HMS-INS-Rev 1b

For Use with 1-1/2 Inch through 3 Inch Booms

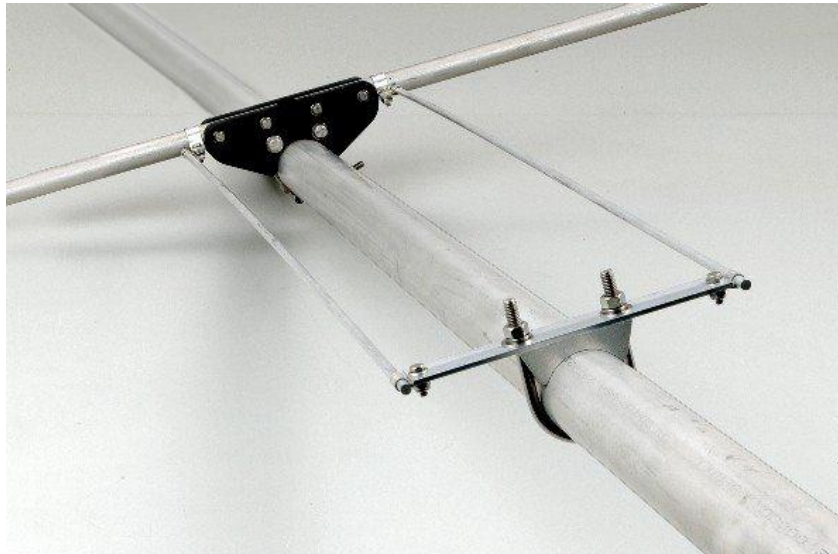

Shown with optional boom, elements and Element Bracket with hardware

© DX Engineering 2012
P.O. Box 1491 · Akron, OH 44309-1491
Phone: (800) 777-0703 · Tech Support and International: (330) 572-3200
Fax: (330) 572-3279 · E-mail: DXEngineering@DXEngineering.com

Introduction

The DX Engineering **HMS** Hairpin Matching Systems is a convenient way to match the feedpoint impedance of a Yagi antenna with coaxial cable. While the hairpin has been popular with radio operators for years, this model improves on the classic design by using adjustable rods to quickly match Yagi antennas. The stainless steel rods not only make the antenna easier to adjust than conventional wire loop hairpins, the **HMS** Hairpin Matching System adds rigidity, offers better protection against ice and wind, and adds a professional appearance.

The driven element must be insulated from the boom of the antenna, and it must be split so the element halves are also insulated from each other.

Features

- Has the correct electrical and mechanical design to allow it to be easily installed and tuned.
- Has enough capacity for almost any Yagi design.
- Includes two rods and all necessary hardware.
- Allows balanced distribution of RF current.

Theory of Operation

Many directly fed Yagi antennas have feedpoint impedances of approximately 20 to 25 Ohms, which becomes a problem for those who want to connect to 50 Ohm coaxial cable. An easy way to accomplish this is to modify the antenna with a U-shaped conductor known as a “Hairpin” or Beta Match.

The hairpin is really a simplified L-matching network. The driven element creates a capacitive component of the impedance, and the U-shape of the Hair Pin Matching System components that span the driven element provides the inductive component. The hairpin’s electrically neutral center attaches to the boom.

The **HMS** Hairpin Matching Systems features a sliding bracket that adjusts the impedance between the antenna and transmission line. For more information about hairpin matching technology, refer to *The ARRL Antenna Book* or other reliable sources.

The Hairpin Matching System does not take the place of a high quality current choke balun. Excellent results from a Yagi depend upon current balance, a feature of the split driven element antenna that can take advantage of the balanced nature of the hair pin match. The use of a **DX Engineering Balun** is highly recommended and is described in this manual.

Models Available

There are three models available:

Model	Boom Size - Inches	Rod Length - Inches
DXE-HMS-2P	1.50 to 1.75	11.5
DXE-HMS-1P	2	36
DXE-HMS-4P	3	36

DXE-HMS-2P - Hairpin Matching System, 1-1/2 in to 1.75 in Boom

Most Yagi antennas have a low feedpoint impedance, which differs from the 50-ohm feed line that most of us use. Our Hairpin Matching Kit includes all of the items that you need to match your antenna to a 50-ohm feed line without so much as drilling a hole in most instances.

Our Hairpin is balanced and easy to tune. It has the correct electrical and mechanical design to allow it to be easily installed and tuned in 10 minutes and has enough capacity for almost any Yagi design.

- Has the correct electrical and mechanical design to allow it to be easily installed and tuned in 10 minutes
- Has enough capacity for almost any Yagi design.
- Includes two 11½" rods and all necessary hardware.
- DXE-BEB-3 Bracket NOT included



DXE-HMS-1P - Matching System, 2 in. Boom

Most Yagi antennas have a low feedpoint impedance, which differs from the 50-ohm feed line that most of us use. Our Hairpin Matching Kit includes all of the items that you need to match your antenna to a 50-ohm feed line without so much as drilling a hole in most instances.

The DX Engineering Hairpin is balanced and easy to tune. It has the correct electrical and mechanical design to allow it to be easily installed and tuned in 10 minutes and has enough capacity for almost any Yagi design.

- Has the correct electrical and mechanical design to allow it to be easily installed and tuned in 10 minutes
- Has enough capacity for almost any Yagi design.
- Includes two 36" rods and all necessary hardware.
- DXE-BEB-2 Bracket NOT included



DXE-HMS-4P - Hairpin Matching System, 3 in. Boom

Most Yagi antennas have a low feedpoint impedance, which differs from the 50-ohm feed line that most of us use. Our Hairpin Matching Kit includes all of the items that you need to match your antenna to a 50-ohm feed line without so much as drilling a hole in most instances.

The DX Engineering Hairpin is balanced and easy to tune. It has the correct electrical and mechanical design to allow it to be easily installed and tuned in 10 minutes and has enough capacity for almost any Yagi design.

- Has the correct electrical and mechanical design to allow it to be easily installed and tuned in 10 minutes
- Has enough capacity for almost any Yagi design.
- Includes 36" rods and all necessary hardware.
- DXE-BEB-1 Bracket NOT included



Assembly

1. Refer to Figure 1, and then slide a large P-clamp on either end of the driven element so that the clamps touch the boom to element bracket. (**Note:** The driven element must be "split" so that the left and right elements are insulated from each other and from the boom. When installing stainless steel hardware, it is suggested that **UMI-81343, 81464, DXE-NSBT8, NMBT8 - Never-Seez** or **Anti-Seize** be used to prevent thread galling on stainless steel.

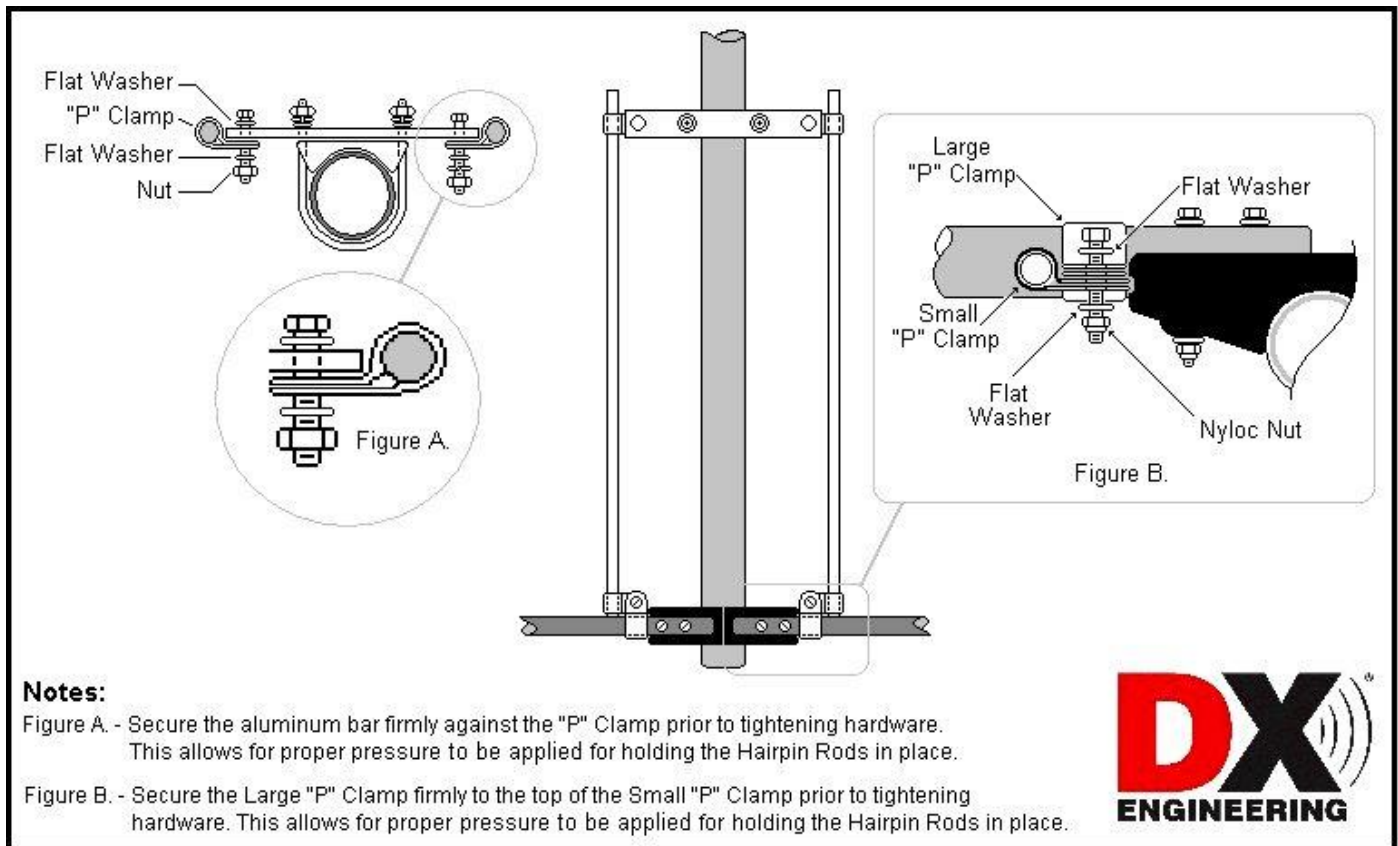

Figure 1

A suggested forming technique: Once the clamps have been closed by hand around the elements or rods, check the mounting hole alignment. If needed, use a pair of pliers, placing the jaws between the front and the back of the clamp. Apply pressure slowly to the clamp until the clamp mounting holes are aligned

2. Insert an 11½" hairpin rod through a small P-clamp, and then slip that clamp under the large P-clamp as shown in Figure 2.



Figure 2

3. Place a washer over the top of the large P-clamp and over the bottom of the small P-clamp, then insert a bolt through the clamps (see **Figure 2**). Tighten the locking nuts.
4. Using the saddle clamp and U-bolt, attach the hairpin mounting bracket to the boom as shown in **Figure 1**. Be sure to place a flat washer and lock washer between the nut and the hairpin mounting bracket. *Note: The flat washer mounts against the bracket; the lock washer mounts atop the flat washer.*
5. Insert the unattached end of the hairpin rod through the small P-clamp on either end of the hairpin mounting bracket as shown in **Figure 3**. (The P-clamp mounts under the hairpin bracket.) Secure the rod with a bolt and lock nut, making sure to use flat washers on both sides of the clamp.

Figure 3

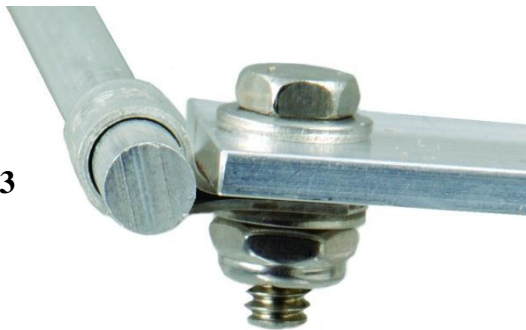

6. Repeat steps 2, 3 and 5 to attach the other rod.

If you are mounting a balun, it should be mounted on the boom as close to the driven elements as possible, on the opposite side from the hair pin match (see **Figure 4**). The balun cannot be mounted in between the hair pin rods. The balun connections from the balanced terminals should be done using either aluminum strap or #10 or #12 AWG copper stranded wire with lug ends and connected directly to the driven elements. If you choose to use the hairpin matching clamp hardware, position the wire lug underneath the rod clamps, before the flat washer and nut. Keep the wires as short as possible, but do not allow the feed wires to touch the boom bracket or boom. The wire or strap should have a drip loop which is also used for reduced vibration stress.

The correct balun for use with the hairpin assembly is a 1:1 current balun. The suggested DX Engineering current balun part numbers are: **DXE-BAL050-H10-A**, **DXE-BAL050-H05-A** or the **DXE-BAL050-H11-C**, depending on power level and environment. Boom or mast mounting kits for DX Engineering baluns are available, as pictured in **Figure 4**.

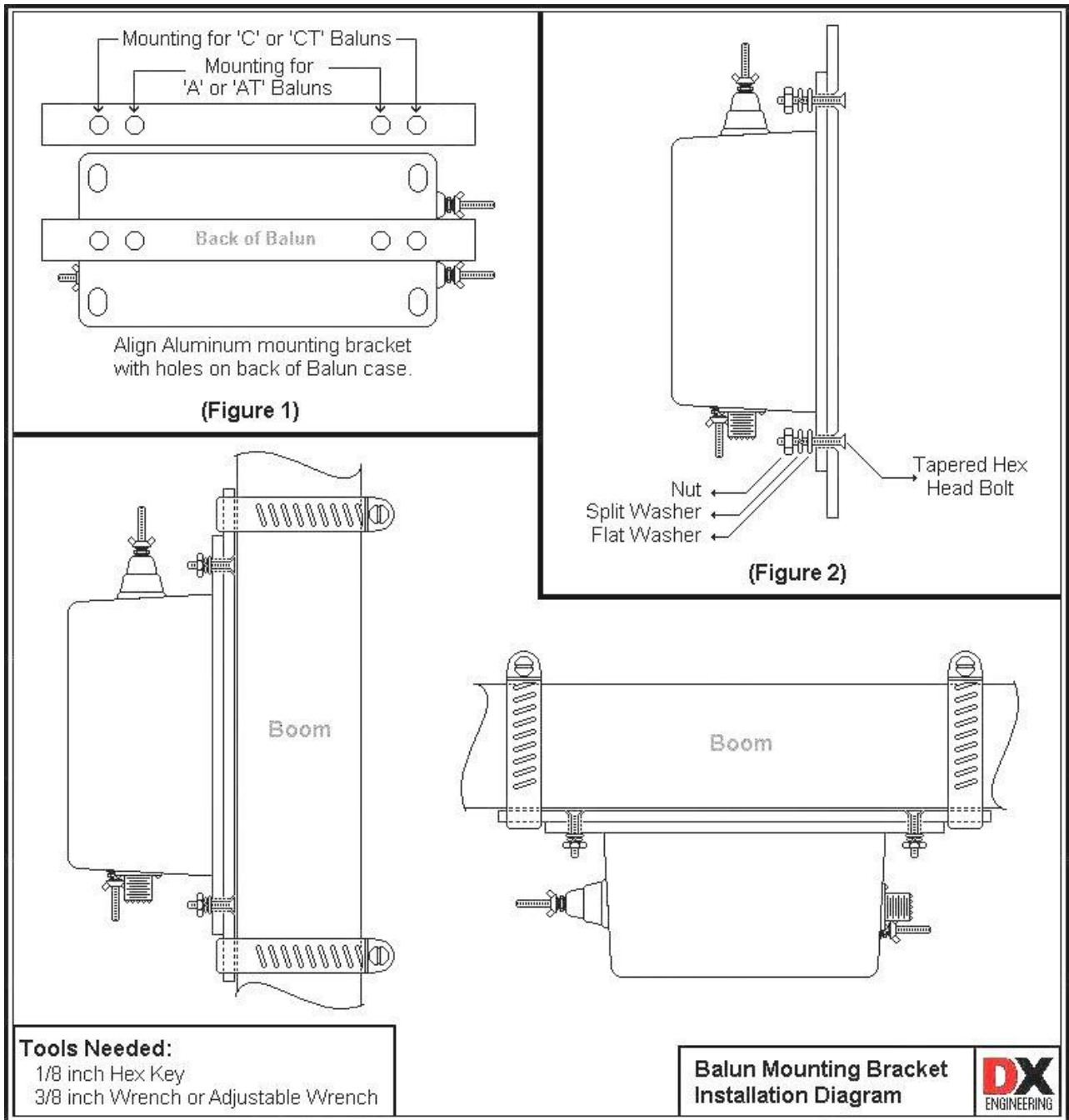

Figure 4

Tuning

To tune the hairpin matching unit, do the following:

1. Make sure the rods are parallel to the boom along their entire length. Adjust the driven element rod spacing if necessary, then tighten hardware securely. The matching adjustment is done by moving the boom bracket toward or away from the driven element.

2. Attach an antenna tuner or network analyzer at the antenna feedpoint. Matching adjustments are commonly done with the balun attached. Most prefer to use an antenna analyzer, like the MFJ-259B, to facilitate the process. This should be done as high above the ground as possible, since close proximity to ground will affect the tuning of any antenna. Often, a step ladder is used to accomplish the tuning procedure. Use a short piece of 50 Ω feedline (6 foot long is best) to connect the analyzer to the balun or the driven element feedpoint. Tune the analyzer to the resonant frequency, then slowly slide the Hairpin boom bracket/shorting bar to obtain the best SWR. Make sure all the clamps except the shorting bar hardware are tight before taking measurements. Depending on the type of antenna, shortening of the driven element from its otherwise resonant length is usually necessary when using a Hairpin Match. The boom hairpin bracket and driven element length combination may have to be adjusted several times to achieve the best setting. Final tuning is ideally done on the tower at the final installed height.

Ground-based adjustments can be done successfully by orienting the boom vertically, aiming up, over a hard surface (concrete or asphalt) and away from structures. With the reflector off the ground, perform the matching procedure listed above. There may be a slight shift of SWR once the antenna is mounted at the final height. The ARRL Antenna Book contains more information about feedline coupling and adjustments.

3. Slide the hairpin mounting bracket until the SWR reaches the lowest value at the desired frequency. See **Figure 5**. *Note: Since the hairpin lengthens the antenna, you may need to shorten the driven element.*

Figure 5

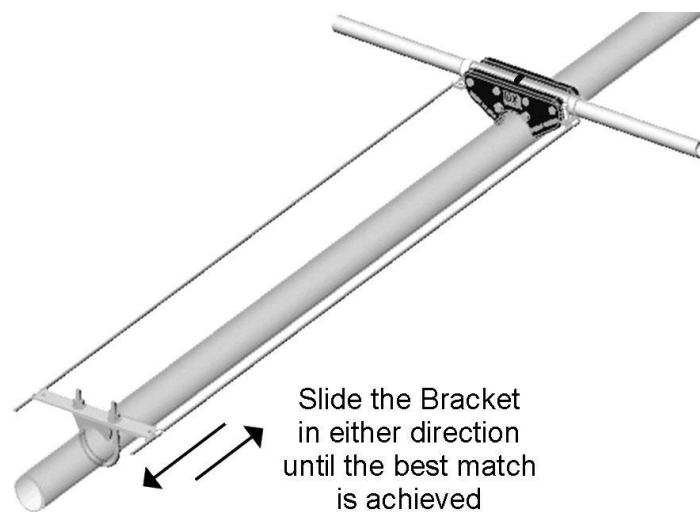

4. When completed, tighten all nuts on the hairpin. It is not necessary to cut off excess rod length.

Optional Items

DXE-BEB-1 - Insulated 3 in. Boom to Element Bracket

The BEB-1 is used to replace KLM or DX Engineering boom to element brackets or for any other application where insulated elements are desired. DX Engineering brackets are made from a much stronger material and have a vastly improved design. They are 5 times as strong as the original brackets and allow use of up to 1.25" outside diameter element tubing.

The DX Engineering brackets allow use of DX Engineering's Gorilla Grip™ stainless steel boom clamps which will end all of your concerns about elements rotating on the boom.

These Boom to Element Brackets are made for 3" O.D. booms only.

For 2" booms please use DXE-BEB-2



DXE-BEB-1HWK - Hardware Kit for Mounting the DXE-BEB-1 Bracket to the Boom

Includes the Gorilla Grip™ stainless steel boom clamps, the stainless steel bolts, nuts and washers that attach them to the DXE-BEB-1 element bracket. Also included are the stainless steel bolts, nuts and washers that attach the elements and/or adaptors to the element brackets. Nuts are vibration resistant nylon insert types. This hardware kit is designed as a direct KLM hardware replacement. It uses number 10 fasteners for the elements.

- Stainless Steel hardware
- Vibration resistant nuts



DXE-BEB-1HWK-2 - Heavy Duty Boom to Element Bracket Hardware Kit for Mounting the DXE-BEB-1 Bracket to the Boom. Utilizes 1/4 in. Bolts Instead of #10 Fasteners

This kit includes all the same hardware as DXE-BEB-1HWK, except we swapped out the #10 fasteners and replaced them with 1/4" bolts. Unlike DXE-BEB-1HWK, this hardware kit is **NOT** a direct replacement for KLM brackets/hardware. When using this hardware kit with our DXE-BEB-1 Element Brackets, please be advised that the pre-drilled holes in KLM elements were designed for #10 fasteners. You may need to modify the size of the holes in the element to accommodate the 1/4" bolts in this kit. If you do not want to resize the holes in your elements then you should use the DXE-BEB-1HWK.

- Stainless Steel hardware
- Vibration resistant nuts



DXE-BEB-2 - Insulated 2 in. Boom to Element Bracket

It is a convenient, low cost method for the insulated attachment of elements when building Yagi, LPDA or other antennas on 2" booms. The DX Engineering Boom-to-Element Bracket will separate and insulate the element from the boom thereby requiring no element length corrections. You can cut the tubing just like the antenna design program tells you and it will work as well as your computer model! It accepts up to a 7/8" element, which is suitable for antennas built for 6 meters up thru 20 meters with reasonable wind survivability. The DXE-BEB-2 comes in 2 pieces and bolts together with a DXE-BEB-2HWK stainless steel hardware clamp kit which also holds it securely to the boom. The DXE-BEB-2 is made from an extremely strong polymer that is also highly UV resistant. When bolted to your 2" boom with our hardware kit, it will easily support a split 20-meter element *without* a fiberglass centerpiece.



DXE-BEB-2HWK - Hardware Kit for Mounting the DXE-BEB-2 Bracket to the Boom

The DXE-BEB-2HWK is used with the DXE-BEB-2 to clamp the two halves of the insulator together and to clamp the assembly to the 2" boom. Includes 4 stainless steel bolts, washers and lock nuts that securely clamp the 2 element halves together, a Gorilla Grip™ stainless steel boom clamp, the stainless steel bolts, nuts and washers that attach it to the element bracket. Nuts are vibration resistant nylon insert types.

- Stainless Steel hardware
- Vibration resistant nuts



DXE-ELA-1-2 - Element Adaptors That Allow the Use of 1 in. Diameter Elements with the DXE-BEB-1 Bracket

Allows the use of our Extreme Duty Boom to Element Brackets (DXE-BEB-1) with 1" O.D. element tubing as used on original KLM or DXE antennas. Bolts included with DXE-BEB-1HWK Hardware Kit.



DXE-BAL050-H05-A - Balun - 1:1, 1.8 to 30 MHz, Formed Aluminum Enclosure (Wire Dipoles)

DX Engineering High Power Transmission Line Transformers and Baluns with Maxi-Core™ Technology, allows your antenna perform to its full potential and reduces the stresses on your equipment.

They deliver the power to your antenna with minimum loss and perform a perfect transition from balanced to unbalanced. This results in the strongest signal your antenna's capable of producing with the lowest SWR under given conditions. While each of the DX Engineering baluns have been designed with a safety factor for power, the DXE-BAL050-H05-A will handle more than its rated power on a regular basis. Under higher mismatch conditions, if you run more than 1500 watts and are little unsure of the environment in which your balun will be place then you should order the DXE-BAL050-H10-A.

- 1.8 – 30 MHz operating range to cover popular amateur bands.
- Smaller size and weight make it an ideal choice for a wire antenna balun
- Provides a great match between the coax impedance and the antenna impedance for the lowest SWR.
- Performs at the highest levels of efficiency so there is little signal loss in both transmit or receive applications.
- Handles rated power with minimal energy loss so there is no thermal related failure.



DXE-BAL050-H10-A - Balun - 1:1, High Power, 1.8 to 30 MHz, Formed Aluminum Enclosure

The DX Engineering High Power 1:1 Balun with Maxi-Core™ Technology, allows your antenna to perform to its full potential while reducing the stress on your equipment. It delivers the power to your antenna with minimum loss and performs a perfect transition from balanced to unbalanced by fully decoupling the feedline from your antenna, improving efficiency and reducing RFI. This results in the strongest signal your antenna's capable of producing with the lowest SWR under given conditions.

- 1.8 – 30 MHz operating range to cover popular amateur bands.
- Provides a great match between the coax impedance and the antenna impedance for the lowest SWR.
- Performs at the highest levels of efficiency so there is little signal loss in both transmit or receive applications.
- Handles rated power with minimal energy loss so there is no thermal related failures.



DXE-BAL050-H11-C - Balun - 1:1, High Power, 1.8 to 30 MHz, Cast Aluminum Gasketed Enclosure DX

Engineering High Power Transmission Line Transformers and Baluns with Maxi-Core™ Technology, allows your antenna perform to its full potential and reduces the stresses on your equipment. They deliver the power to your antenna with minimum loss and perform a perfect transition from balanced to unbalanced. This results in the strongest signal your antenna's capable of producing with the lowest SWR under given conditions.

- 1.8 – 30 MHz operating range to cover popular amateur bands.
- Provides a great match between the coax impedance and the antenna impedance for the lowest SWR.
- Cast Aluminum Gasketed Enclosure for protection from environment.



Balun Mounting Kit

This handy Aluminum mounting bar and Stainless Steel hardware kit will allow you to mount your quality DX Engineering Balun, Feed Line Current Choke, or Vertical Feedline Current Choke, directly to a boom or pipe.

Kits include:

- (1) Mounting Bracket (1) Bracket Hardware Kit
- (2) Boom Clamps
- Bar Material: Aluminum
- Bar Hardware and Element Clamp Material: Stainless Steel
- Bar Dimensions: 10 x 1.00 x .125 (inches)



DXE Part Number	Boom Size
DXE-BMB-1P	0.750 inch through 1.50 in inch
DXE-BMB-2P	1.560 inch through 2.25 inch
DXE-BMB-3P	2.31 inch through 3.00 inch

UMI-81343, DXE-NSBT8 - Anti-Seize & Never-Seez

An Anti-seize compound MUST be used on any Stainless Steel nuts, bolts, clamps or other hardware to prevent galling and thread seizure. Any of these products can be used for this purpose.

*UMI-81343	Anti-Seize, 1 oz. Squeeze Tube
*UMI-81464	Anti-Seize, 8.5 oz. Aerosol Can
*DXE-NSBT8	Never-Seez, 8 oz. Brush Top
*DXE-NMBT8	Never-Seez, 8 oz. Brush Top, Marine Grade

*** These products are limited to domestic UPS Ground shipping only**



DXE-P8A - Penetrox A Anti-Oxidant - 8 oz Squeeze Bottle

Use Penetrox A electrical joint compound to affect a substantial electrical connection between metal parts such as telescoping aluminum tubing or other antenna pieces. Ensures high conductivity at all voltage levels by displacing moisture and preventing corrosion or oxidation. For Aluminum to Aluminum, Aluminum to Copper, or bare conductors. Not recommended for use with rubber or polyethylene insulated wire.

- 8 oz. squeeze bottle

*** This product is limited to domestic UPS Ground shipping only**



DXE-SOF-YAGIMECH30 - Yagi Mechanical® Antenna Design Software

Yagi Mechanical® is a software tool for anyone who designs antennas, or is looking into doing so. Electrical design is first and foremost in designing a useful antenna. Just as important, but often overlooked, is the mechanical side of the design. What good is a great performing antenna if the wind or ice accumulation is going to break the elements after you put it on the tower.

Use Yagi Mechanical to find weak points in old designs or to start brand new designs with robust mechanical properties. Enter the design Frequency, Windspeed, # of Elements and Tubing size and YM will provide you with the software tools you need to test your design for wind and ice survivability and to balance weight and torque on the boom. Alter the mechanical properties of the design until your design parameters are met. Yagi Mechanical can export directly into EZNEC, YO or AO. It can also import directly from YO.

Call it good planning for the kind of stress your antennas are going to see.

Call it smart design to keep from having to do regular repairs.

Call it peace of mind for a cheap price. We call it Yagi Mechanical®.

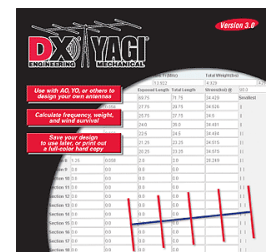

Notes:

Technical Support

If you have questions about this product, or if you experience difficulties during the installation, contact DX Engineering at (330) 572-3200. You can also e-mail us at:

DXEngineering@DXEngineering.com

For best service, please take a few minutes to review this manual before you call.

Warranty

All products manufactured by DX Engineering are warranted to be free from defects in material and workmanship for a period of one (1) year from date of shipment. DX Engineering's sole obligation under these warranties shall be to issue credit, repair or replace any item or part thereof which is proved to be other than as warranted; no allowance shall be made for any labor charges of Buyer for replacement of parts, adjustment or repairs, or any other work, unless such charges are authorized in advance by DX Engineering. If DX Engineering's products are claimed to be defective in material or workmanship, DX Engineering shall, upon prompt notice thereof, issue shipping instructions for return to DX Engineering (transportation-charges prepaid by Buyer). Every such claim for breach of these warranties shall be deemed to be waived by Buyer unless made in writing. The above warranties shall not extend to any products or parts thereof which have been subjected to any misuse or neglect, damaged by accident, rendered defective by reason of improper installation, damaged from severe weather including floods, or abnormal environmental conditions such as prolonged exposure to corrosives or power surges, or by the performance of repairs or alterations outside of our plant, and shall not apply to any goods or parts thereof furnished by Buyer or acquired from others at Buyer's specifications. In addition, DX Engineering's warranties do not extend to other equipment and parts manufactured by others except to the extent of the original manufacturer's warranty to DX Engineering. The obligations under the foregoing warranties are limited to the precise terms thereof. These warranties provide exclusive remedies, expressly in lieu of all other remedies including claims for special or consequential damages. SELLER NEITHER MAKES NOR ASSUMES ANY OTHER WARRANTY WHATSOEVER, WHETHER EXPRESS, STATUTORY, OR IMPLIED, INCLUDING WARRANTIES OF MERCHANTABILITY AND FITNESS, AND NO PERSON IS AUTHORIZED TO ASSUME FOR DX ENGINEERING ANY OBLIGATION OR LIABILITY NOT STRICTLY IN ACCORDANCE WITH THE FOREGOING.

©DX Engineering 2012

DX Engineering®, DXE®, DX Engineering, Inc.®, Hot Rodz™, Maxi-Core™, THUNDERBOLT™, Antenna Designer™, Yagi Mechanical™, and Gorilla Grip® Stainless Steel Boom Clamps, are trademarks of PDS Electronics, Inc. No license to use or reproduce any of these trademarks or other trademarks is given or implied. All other brands and product names are the trademarks of their respective owners.

Specifications subject to change without notice.

